

Dillon Square Deal 'B'

Instruction Manual

May 2007



Square Deal B Parts List

Stock #	Description	13864	Switch Lever
11628	Bullet Seater Insert	13865	Powder Die
11734	Crimp Insert	13871	Bellcrank Cube
*12124	Seating Stem	13879	Primer Magazine – Small
12864	Carbide Sizer Insert	13882	Powder Measure Lid
13028	Square Deal B Manual	13893	Powder Bar Post – Large
13328	Shellplate Bolt	13895	Clamp Screw
*13427	Powder Funnel	13896	1/4-20 3/8 BH Screw
13429	Decap Pin Nut	13908	Crimp Adjustment Screw
13433	Ejector Wire	13921	Powder Measure Spacer Plug
13437	Shaft	13943	Powder Bar Adjustment Bolt
13444	Overtravel Block Bolt	13944	Indexer Return Spring
13445	Square Deal Frame	13945	Pivot Bolt Wave Washer
13461	Index Bolt	13951	Powder Bar Post – Small
13479	Spent Primer Track Cover	13957	Primer Shield Cap
*13504	Shellplate	13958	Powder Bar Washer
13597	Over Travel Block	13961	Primer Adjustment Screw
13621	Primer Cup – Large	13964	Spring Screw
13622	Crank Pin	13967	Primer Punch – Large
13624	Indexer Spring (RL1000)	13976	Chute Bracket Screw
13644	Smaller Powder Bar Spacer	13979	Primer Return Pin Spring
13657	Primer Cup – Small	13982	Primer Punch Spring
13659	Chute Bracket	13986	Collar Clamp
13673	Primer Magazine – Large	13989	Feed Body Screw
13689	Primer Slide Roller	13999	Pickup Tube Tip (yellow) - Small
13690	Platform Base Disc	14003	Magazine Orifice (red) - Large
13691	Powder Measure Tube	14010	Pickup Tube Tip (green) - Large
13705	Indexer Pawl	14013	8/32"x3/8" Cap Screw
13707	Follower Rod	14014	10-24x7/8 SHCS
13712	Toolhead Plate	14019	Detent Ball
13714	Indexer Lever	14024	Magazine Orifice (blue) - Small
13718	Crank Pin Set Screw	14033	Primer Cup Spring (RL550B)
13721	Delrin Die Lock/Friction Plate	14036	Powder Bar Spring
13722	Primer Slide Bearing	14037	Clamp/Bracket Screw
13726	Return Spring Roll Pin	14040	Retaining Clip
13739	Detent Spring	14041	Bowed Washer
13754	Primer Slide	14051	Primer Retaining Pin
13756	Bin Box	*14060	Locator Button (3)
13757	Primer Punch – Small	14157	#10 Washer
13764	Powder Die Ring Clamp	14293	Indexer Lever Assembly
13776	Pawl Pin	16211	Spent Primer Cup
13789	Set Screw	16523	Plastic Wave Bearing - 4 pack
13790	Primer Slide Return Pin	16814	Failsafe Rod
13793	Body Collar Roller	17085	Dispensing Tip, Large
13797	Pivot Bushing	17086	Dispensing Tip, Small
13798	Return Spring	17212	Spent Primer Cup/Return Bracket
13799	Blue Failsafe Strip Nut	18077	Brass Link Arm Bearing
13801	Tinnerman Insert	18086	#10 Rod Washer
13809	Roller Bolt	20059	Primer Pickup Tube – Small
14037	Toolhead Mount Screw	20060	Primer Pickup Tube – Large
13818	Powder Bar Insert – Small	20062	Powder Bar Assembly – Small
13822	Link Arm	20063	Powder Bar Assembly – Large
13823	Primer Punch Set Screw	20114	Crank Handle
13828	Link Arm Washer	20302	Complete Early Warning System
13843	Upper Decap Pin	20642	Body Collar Assembly
13845	Collar Sleeve	20900	Primer Feed Body
13847	Overtravel Spring	22200	Decap Stem w/ Cap & Pin
13850	Handle Knob	22273	Powder Measure Body
13853	Powder Bar Insert – Large		
13857	Battery Cover		
13860	Base Disc Screws		

** Indicates a caliber/size specific part. See the caliber conversion chart for the caliber you are loading for.*

Square Deal B Schematic

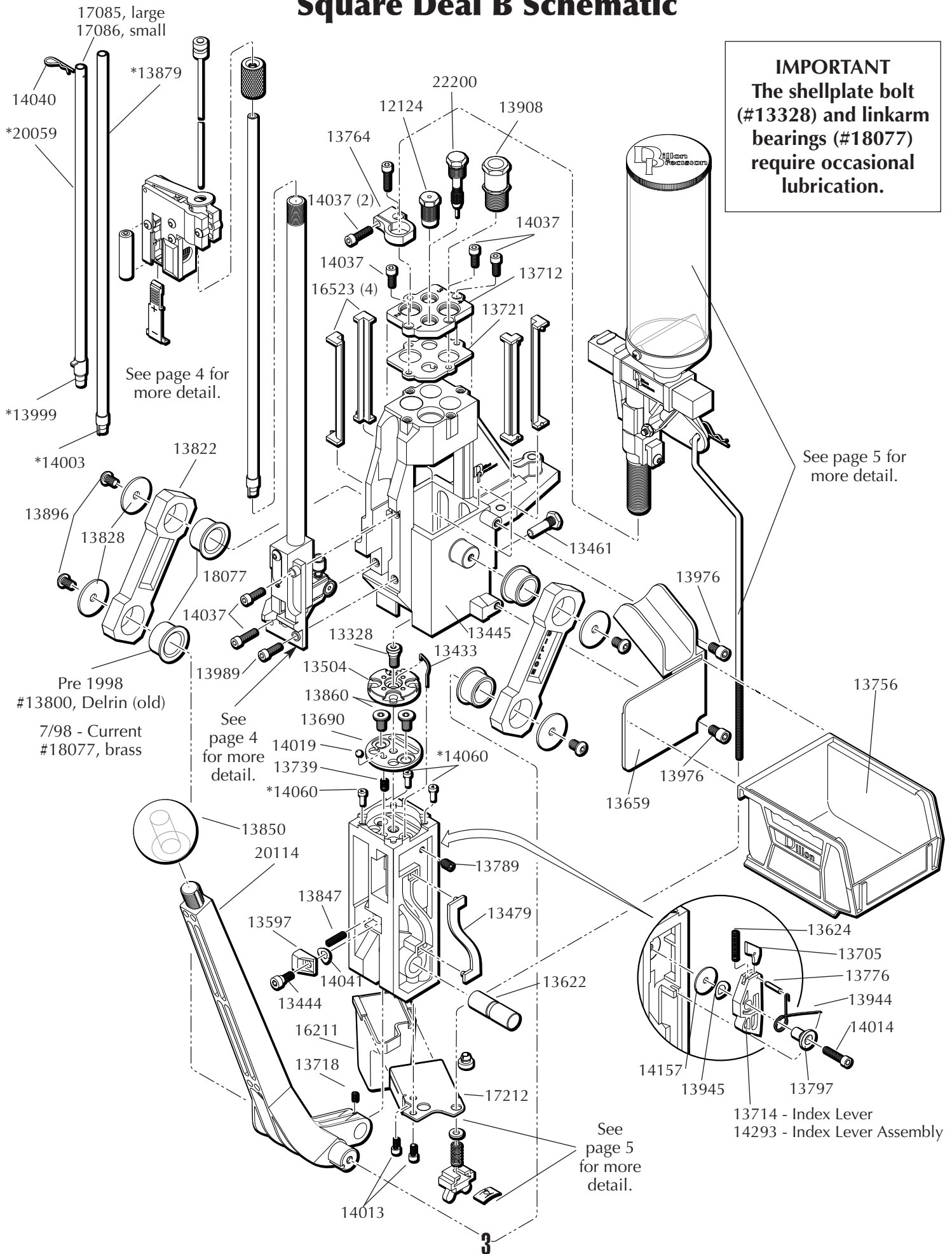

IMPORTANT
The shellplate bolt (#13328) and linkarm bearings (#18077) require occasional lubrication.

Automatic Primer System

20253 large, 20012 small

- 13726 Return Spring Roll Pin
- 13798 Return Spring
- 13957 Primer Shield Cap
- 13961a Primer Feed Adjst Screw
- 13961b Slide Stop Adjst Screw
- 13964 Spring Screw
- 13979 Primer Return Pin Spring
- 13989 Feed Body Screw

- 14037 Bracket Screw
- 14051 Primer Retaining Pin
- 20124 Large Primer Slide Assy
- 20125 Small Primer Slide Assy
- 20900 Primer Housing & Shield
- 22028 Small Primer Pickup Tube
- 22029 Large Primer Pickup Tube
- 22030 Small Primer Magazine Assy
- 22031 Large Primer Magazine Assy

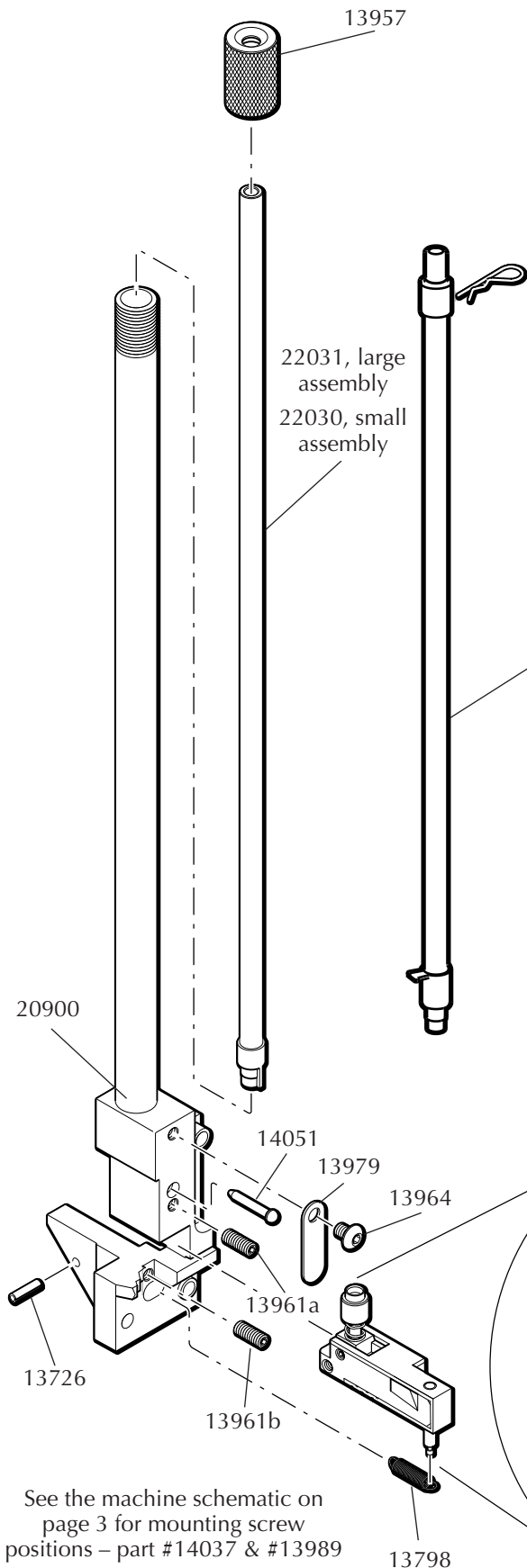

20302 Early Warning System (Complete)

- 13707 Follower Rod
- 13857 Battery Cover
- 13864 Switch Lever

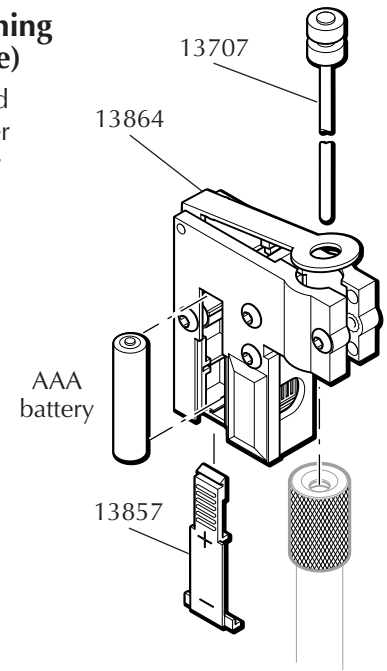

22029, large assembly
22028, small assembly

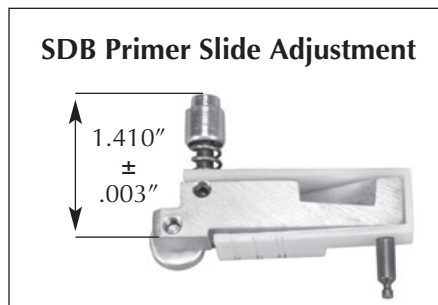

Primer Slide Assembly 20124 large, 20125 small

- 13621 Primer Cup – Large
- 13657 Primer Cup – Small
- 13689 Primer Slide Roller
- 13722 Primer Slide Bearing
- 13754 Primer Slide
- 13757 Primer Punch – Small
- 13790 Primer Slide Return Pin
- 13809 Roller Bolt
- 13823 Primer Punch Set Screw
- 13967 Primer Punch – Large
- 13982 Primer Punch Spring

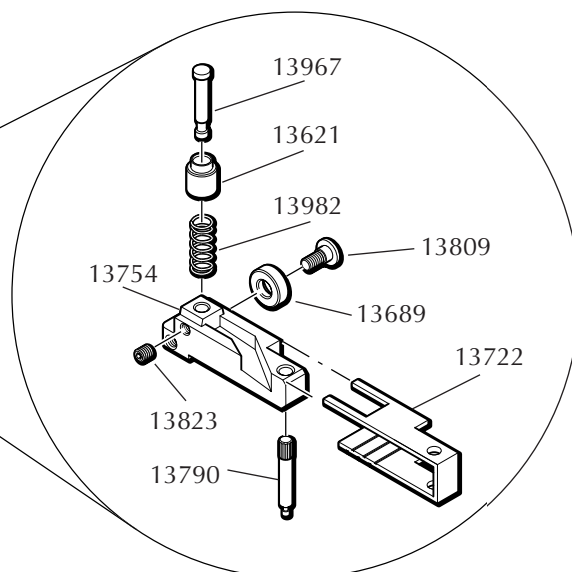

See the machine schematic on page 3 for mounting screw positions – part #14037 & #13989

Okay, It's Here; Now What?

First of all, the Square Deal "B" is a remarkably simple machine and a little care and thought now while you're setting it up will save you time and give you thousands of trouble free rounds.

Mandatory Safety Measures

Reloading ammunition involves the use of highly explosive primers and powder. Handling these materials is inherently dangerous. You should recognize this danger and take certain minimum precautions to lessen your exposure to injury.

Never operate the machine without ear and eye protection on. Call our customer service department at (800) 223-4570 for information on the wide variety of shooting/safety glasses and hearing protection that Dillon has to offer.

- **PAY ATTENTION:** Load only when you can give your complete attention to the loading process. Don't watch television or try to carry on a conversation and load at the same time. Watch the automatic systems operate and make sure they are functioning properly. If you are interrupted or must leave and come back to your loading, always inspect the cases at every station to insure that the proper operations have been accomplished.

- **SMOKING:** Do not smoke while reloading or allow anyone else to smoke in your reloading area. Do not allow open flames in reloading area.

- **SAFETY DEVICES:** Do not remove any safety devices from your machine or modify your machine in any way.

- **MODIFICATIONS:** Any modifications performed to your machine, or the addition of any unapproved equipment from other manufacturers will void the warranty.

- **LEAD WARNING:** Be sure to have proper ventilation while handling lead components or when shooting lead bullets. Lead is known to cause birth defects, other reproductive harm and cancer. Wash your hands thoroughly after handling anything made of lead.

- **LOADS AND LENGTHS:** Avoid maximum loads and pressures at all times. Use only recommended loads from manuals and information supplied by reliable component manufacturers and suppliers. Since Dillon Precision has no control over the components which may be used on their equipment, no responsibility is implied or assumed for results obtained through the use of any such components.

Seat bullets as close to maximum cartridge length as possible. Under some conditions, seating bullets excessively deep can raise pressures to unsafe levels. Refer to a reliable loading manual for overall length (OAL).

- **QUALITY CHECKS:** Every 50-100 rounds, perform quality control checks on the ammunition being produced. Check the amount of powder being dropped and primer supply.

- **RELOADING AREA:** Keep your components safely stored. Clear your work area of loose powder, primers and other flammables before loading.

- **COMPONENTS:** Never have more than one type of powder in your reloading area at a time. Keep containers closed.

Be sure to inspect brass prior to reloading for flaws, cracks,

splits or defects. Throw these cases away.

Keep components and ammunition out of reach of children.

- **BLACK POWDER:** Do not use black powder or black powder substitutes in any Dillon powder measure. Loading black powder cartridges requires specialized loading equipment and techniques. Failure to do so can result in severe injury or death.

- **PRIMERS:** Never force primers. If they get stuck in the operation of the machine, disassemble it and gently remove the obstruction.

Never attempt to clear primers that are stuck in either the primer pickup tube or the primer magazine tube. Never, under any circumstances, insert any type of rod to attempt to force stuck primers out of these tubes. Trying to force primers out of the tube will cause the primers to explode causing serious injury or even death.

If primers get stuck in a primer magazine or pickup tube flood the tube with a penetrating oil (WD-40), throw the tube in the garbage and call us for a free replacement.

Never attempt to deprime live primers – eventually one will go off. When it does it will detonate the others in the spent primer cup. Depriming live primers is the single most dangerous thing you can do in reloading and can cause grave injury or death.

- **LOADED AMMUNITION:** Properly label all of your loaded ammo (date, bullet type, primer, powder, charge, etc.).

- **BE PATIENT:** Our loading equipment is conservatively rated and you should have no trouble achieving the published rates with a smooth, steady hand. If something doesn't seem right, stop, look and listen. If the problem or the solution isn't obvious, call us. The reloading bench is no place to get into a hurry.

We have done everything we know how to make your machine as safe as possible. We cannot, however, guarantee your complete safety. To minimize your risk, use common sense when reloading and follow these basic rules.

- **REMEMBER:** If your machine does not perform to your expectations, or if you are having technical difficulties, give us a call or visit our troubleshooting page online at www.dillonprecision.com

Ready? Let's Set Up

Carefully remove your new Square Deal "B" from its packaging. Set the small parts aside.

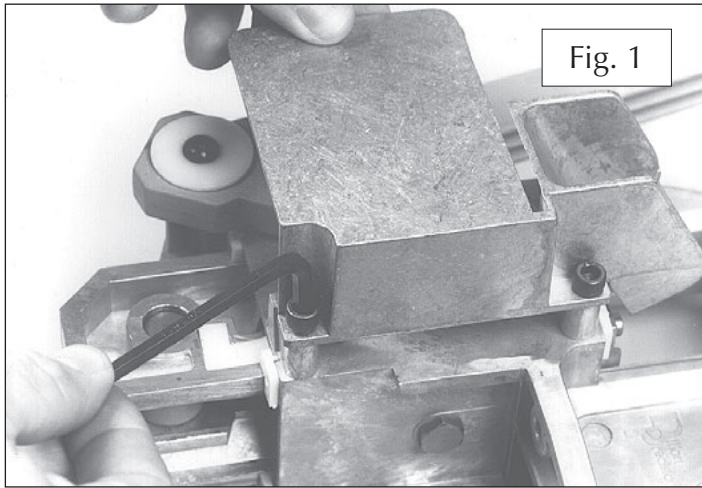

Fig. 1 – Install the ejected cartridge chute bracket (#13659) with two large screws (#13976) from the parts bag.

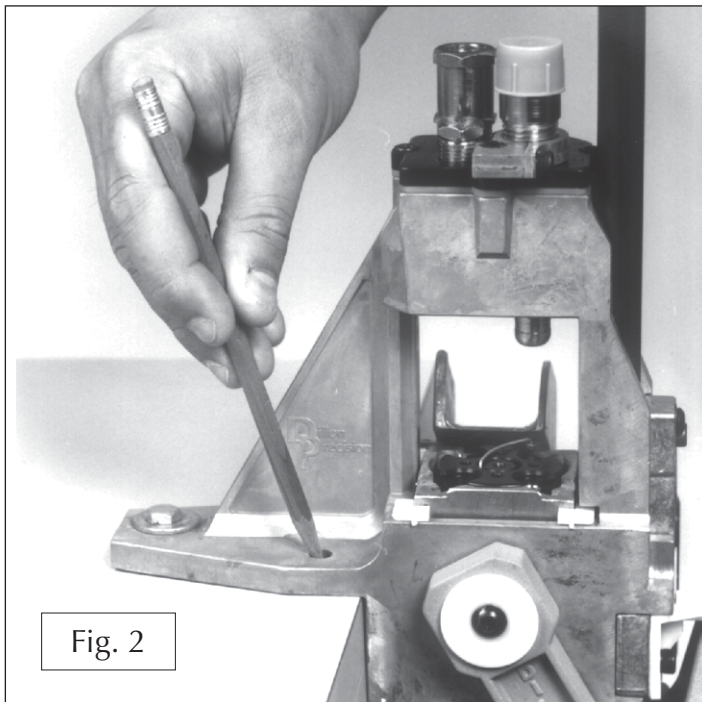

Fig. 2 – Using the machine itself as a template, mark the three mounting holes. Allow about one foot on both sides of your Square Deal "B" for working room. Make sure your bench is sturdy and does not shake, as this may disturb your powder charge and primer system.

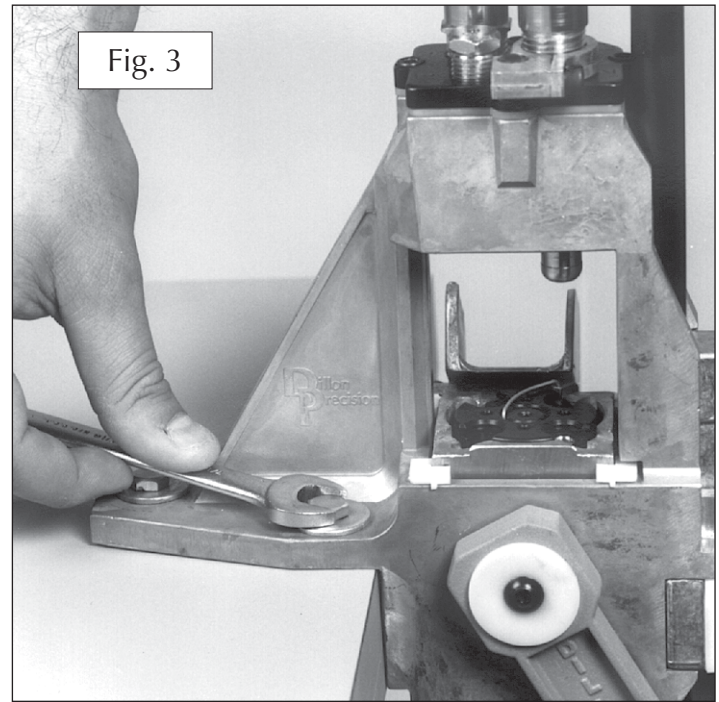

Fig. 3 – Drill the mounting holes and secure the Square Deal "B" to your bench, using 1/4" bolts (not supplied).

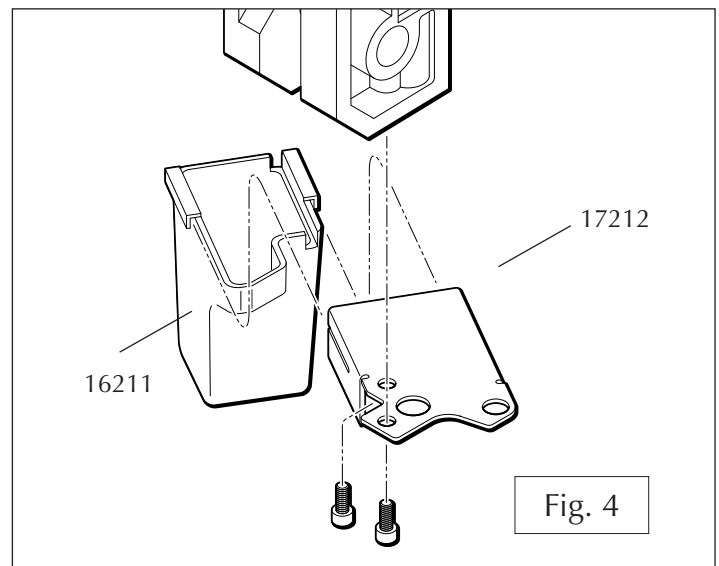

Fig. 4 – Install the spent primer cup/return bracket (#17212) on the bottom of the shaft (#13437). The spent primer cup (#16211) simply slides onto the rails of the bracket.

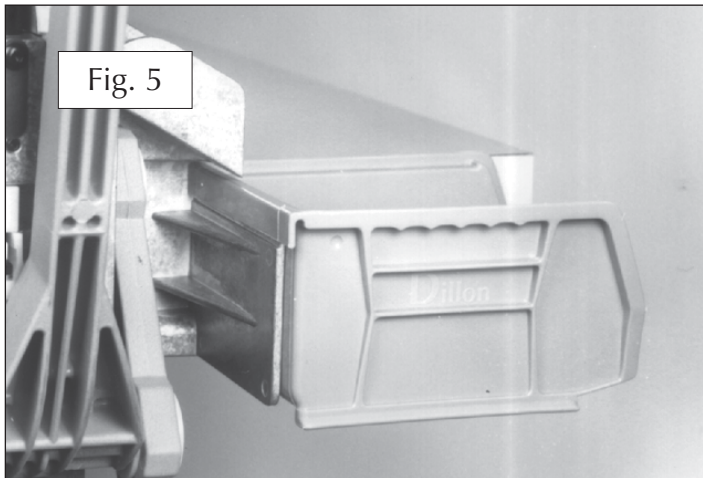

Fig. 5

Fig. 5 – Slide the cartridge collection box (#13756) onto the chute bracket (#13659) as shown.

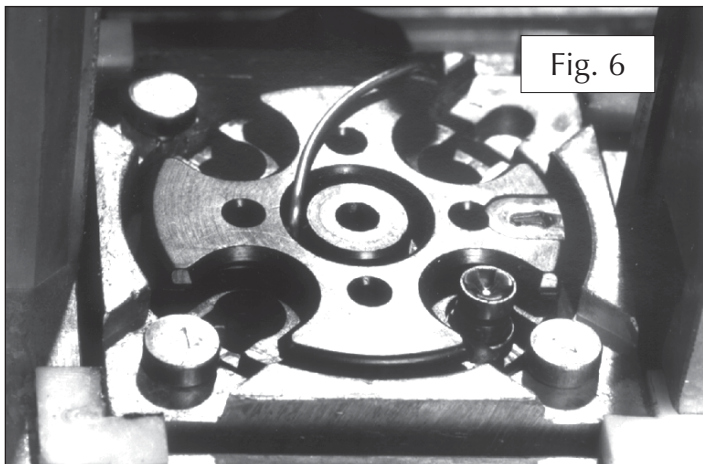

Fig. 6

Fig. 6 – The locator buttons must be placed at Stations 2, 3 and 4 to prevent the cartridge from sliding off of the shellplate. The buttons can be removed to access the case at these stations.

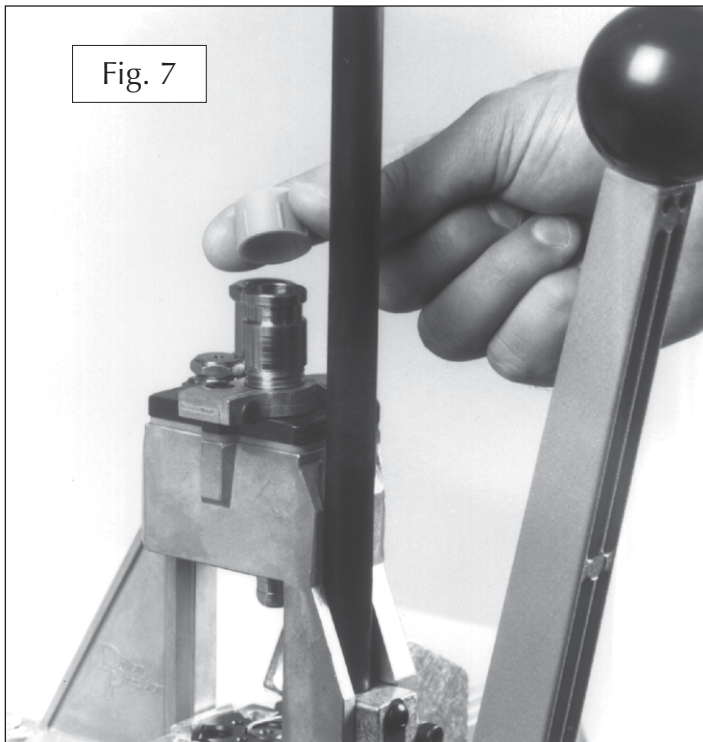

Fig. 7

Fig. 7 – Remove the cap from the top of the powder die (#13865). The cap retains the expander/powder funnel during shipping.

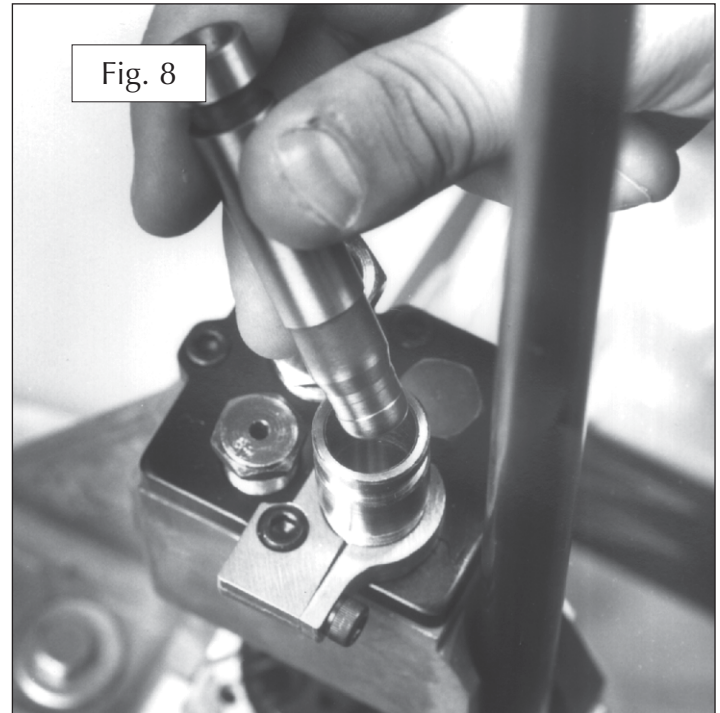

Fig. 8

Fig. 8 – Make sure the expander/powder funnel is free to move in the powder die and reinsert it as shown.

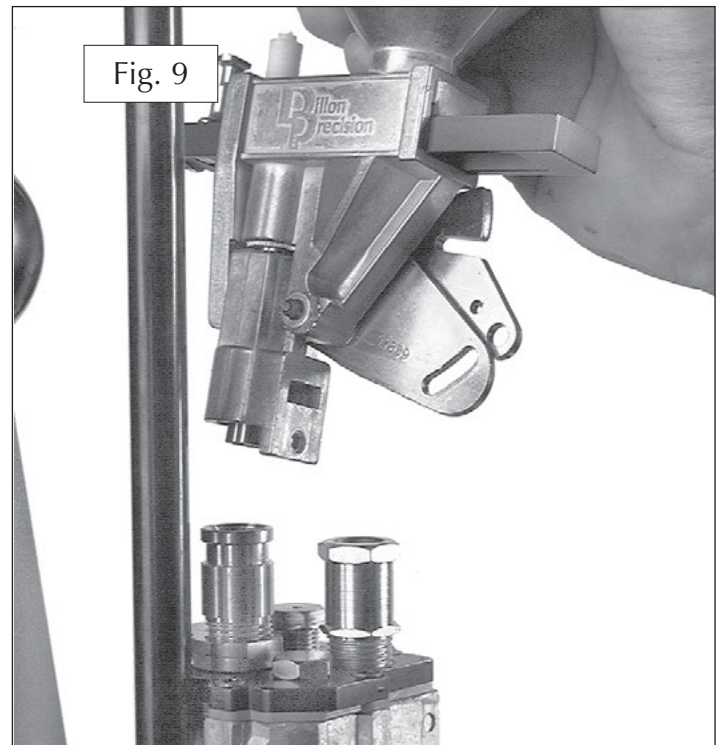

Fig. 9

Fig. 9 – With the cap removed and the expander/powder funnel in position, you are now ready to install the powder measure. Place the powder measure on top of the powder die.

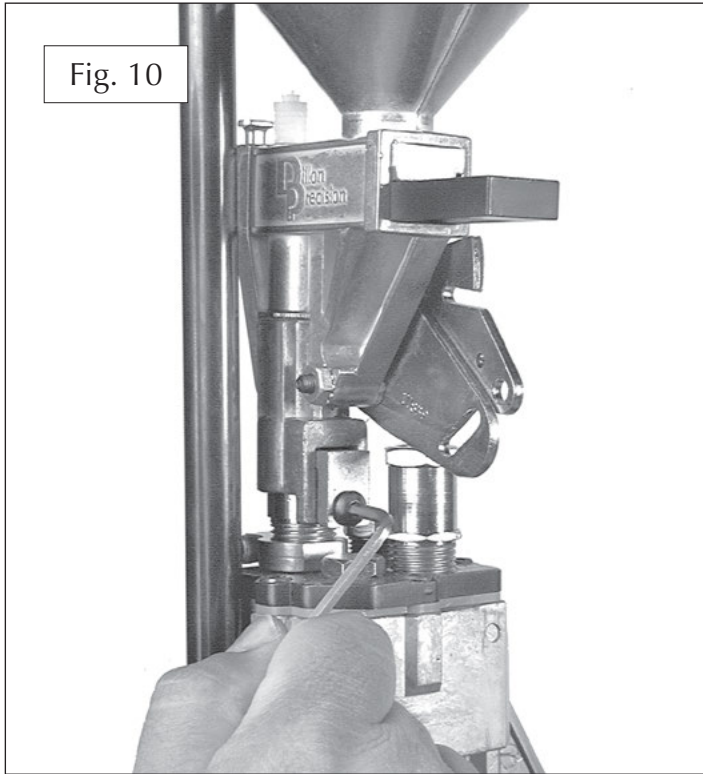

Fig. 10

Fig. 10 – The powder measure is held in place by the collar clamp (#13986). Tighten in place, but do not over tighten.

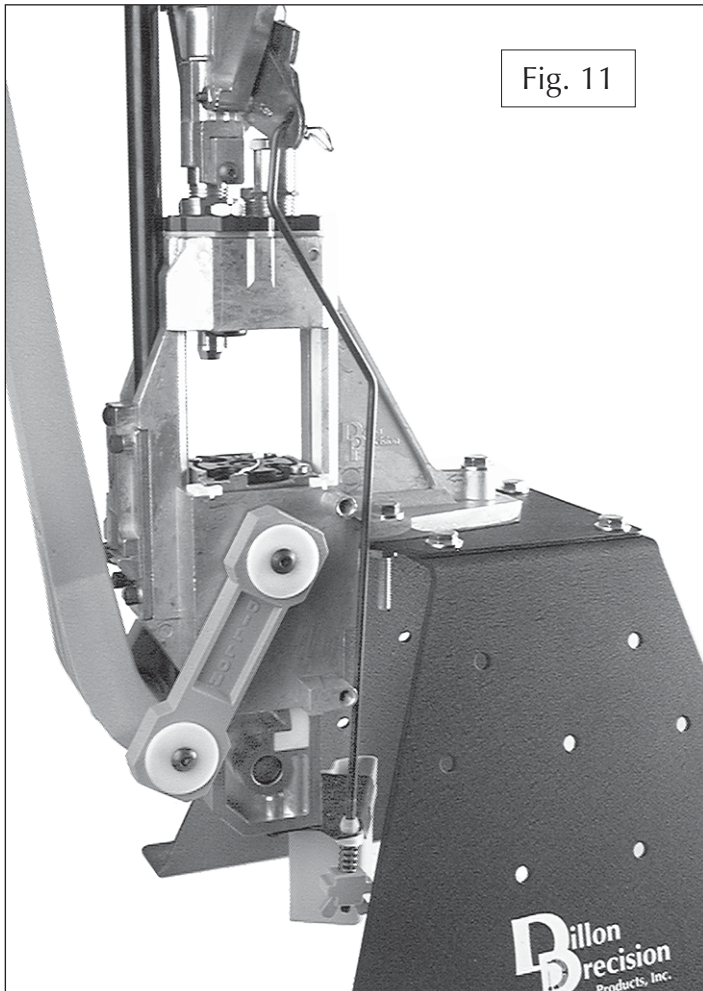

Fig. 11

Fig. 11 & 12 – Installation of the Powder Measure Failsafe System.



Fig. 12

To install the failsafe rod (#16814) remove the blue stripper wingnut (#13799), rod spring (#14033) and washer (#18086). (Note the order of parts.) See Fig. 11

Insert the bottom end of the rod between the bench and the Square Deal “B” through the hole in the return bracket (#13355). Then, using your thumb and index finger of your right hand, move the lock-link (#17838) down to align the hole with the slot on the Powder Measure bellcrank (#17839). Next, insert the failsafe rod (#16814) through the two holes and insert the failsafe rod clip (#13840).

Install the washer (#14033) and the wingnut (#13799). With your left hand, move the operating handle (#20114) to the priming position; press the operating handle firmly forward and with your right hand adjust the wingnut until the spring is partially compressed. You are now ready to reload. Refer to the rear view in Fig. 11 to assist in the rod location and proper powder measure positioning.

Check It Out

Your assembly should now be complete, but before you stock it with powder and primers let’s run through the operation a few times.

Your Square Deal “B” has been adjusted at the factory in the caliber of your choice and we’ve enclosed the sample rounds that we used to obtain those adjustments. One cartridge has a bullet seated to illustrate the seating depth and the other round was primed (the primer is inert).

Place the cartridge case without the bullet in Station 1

and pump the operating handle. The primer will be pushed out and dropped into the spent primer cup (#13651). Continue to pump the handle and observe the advancement of the cartridge from station to station until it is ejected into the cartridge collection box. Now take a new primer and drop it (shiny side down) into the primer magazine (#13673). Operate the handle and the primer will appear at Station 2, press forward on the handle, pick up the primer with your fingers and put it back into the primer magazine. The forward pressure on the handle is important as it exerts the pressure necessary to seat the primer in a cartridge.

Reinsert the case in Station 1, drop the primer in the primer magazine and operate the handle. As the case is moved to Station 2 press forward firmly but gently and you will feel the primer being seated. Cycle the machine and eject the primed round.

IMPORTANT: Let's do it again but this time do not put the primer in the magazine. Repeat the sequence using an unprimed case. Notice how the primer punch tends to stick in the cartridge when no primer is present. This is the feeling you get when your Square Deal "B" runs out of primers.

Now that you've seen the Square Deal "B" function, read the following description of what is happening at each station.

Understanding the Machine

Station 1: When a cartridge is fired, it expands. The carbide resizer returns it to factory dimensions. The primer decap pin knocks out the old primer and deposits it into the spent primer cup.

No adjustments are ever necessary at this station.

Station 2: As you recall, when you press forward on the handle you will seat the primer, but that's not all that's happening here. As the cartridge goes up into the powder measure it encounters a powder funnel that slightly "bells" the mouth of the cartridge – this bell or flare enables you to start your bullet easier at Station 3. As the powder funnel is carried upward by the cartridge it will operate your automatic powder measure and dispense the amount of powder chosen.

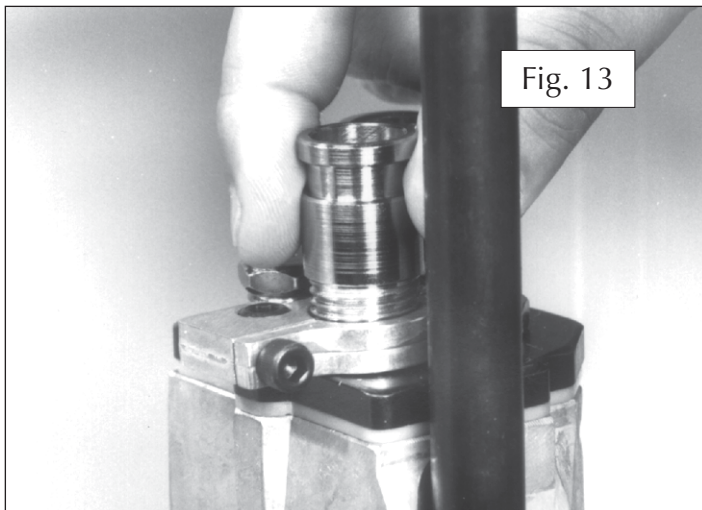

Two adjustments are possible here. The amount of bell has been adjusted at the factory; however, you may increase or decrease the amount of bell by simply screwing the powder die into or out of the toolhead. (See Fig. 13.)

The second adjustment is the most important of the entire loading sequence and must be approached with a great deal of caution. You must adjust your powder measure to meter the proper weight of powder in grains for the load you've selected from a powder manufacturer's chart or reloading manual.

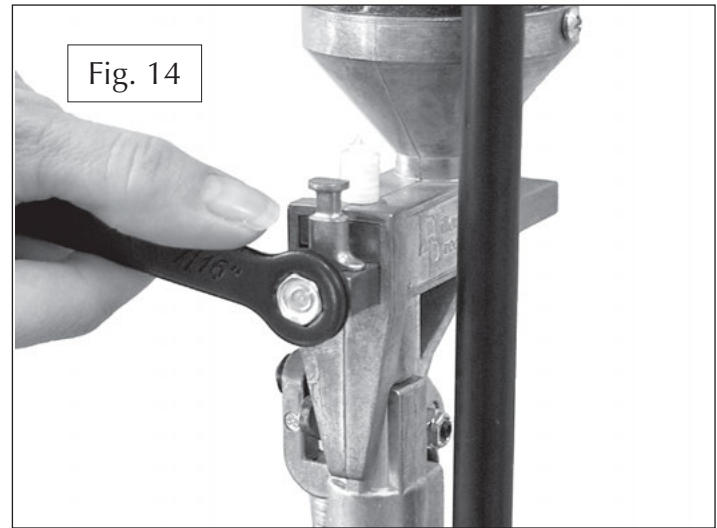

Cycle your empty cartridge into Station 2. Turning the adjusting screw as shown on Fig. 14 will open or close the powder insert. Fill the powder measure with the powder of your choice. Cycle your primed practice round into Station 2 to activate the powder measure. Do this several times and then, using a powder scale, weigh your charge. (See Fig. 15.) Then, by trial and error, continue adjusting until the proper weight of powder is achieved. Run it six more times just to be sure.



With the powder measure up and running let's get some primers.

Fill 'er Up

Using the appropriately sized primer pick up tube,

pick up the primers, shiny side up as shown in Fig. 16. This tube will hold approximately 100 primers.

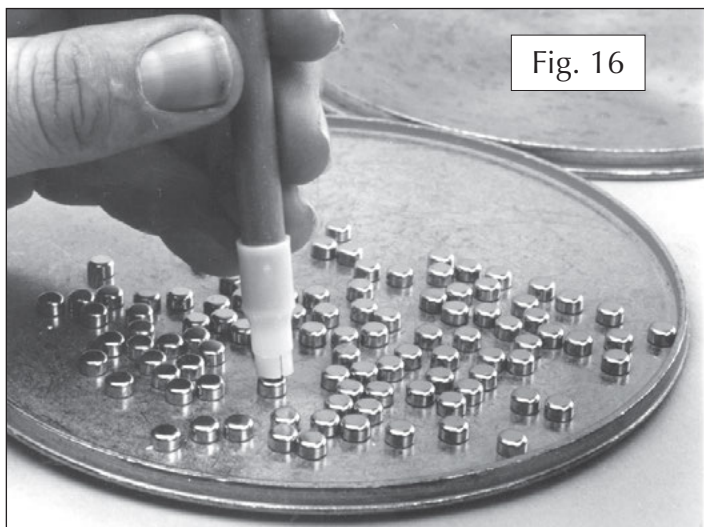

You will notice that the primer magazines and primer pick-up tubes have different colored tips. They have been color coded to help you identify size more easily.

The color code is as follows:

Blue	Small Primer Magazine Orifice
Red	Large Primer Magazine Orifice
Yellow	Small Primer Pick-up Tube
Green	Large Primer Pick-up Tube

Primers are much easier to pick up if you use a primer flip tray. A quality metal tray is available from Dillon Precision.

Never forget that primers are potentially dangerous. Never hit them or attempt to force them.

Primer Early Warning System Installation

(See page 4 for assistance.) Install the battery and the battery cover (#13857) in the system's main body. Slide the Early Warning System Assembly down over the knurled cap on your primer magazine and lightly tighten the clamp screw.

Pivot the switch lever (#13864) away from the Early Warning System housing to fill the primer magazine with primers.

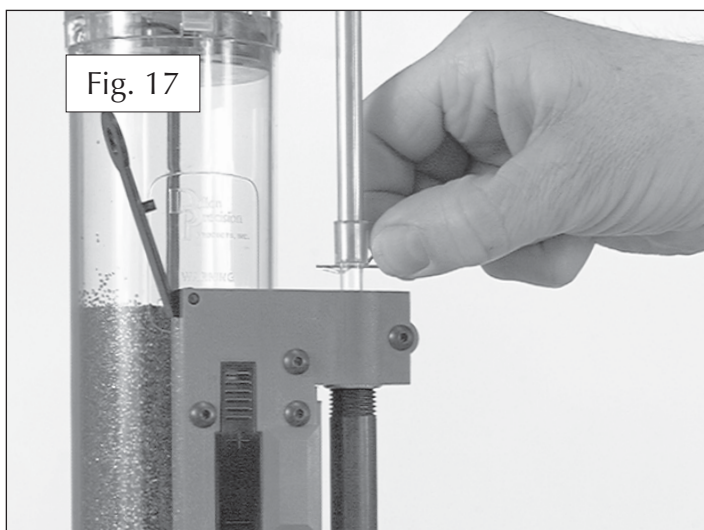

Invert the primer pick up tube over the knurled cap and pull the primer retaining clip (#14040 – See Fig. 17.) The primers should now fall smoothly into the magazine. Pivot the switch lever back over the Early Warning System housing. Gently slide the follower rod (#13707) down through the switch lever, the knurled cap and into the primer magazine tube until the follower rod touches the primers.

You are now ready to reload. When you are nearly out of primers (approximately three remaining) the follower rod will activate the buzzer. Never attempt to remove the primer magazine shield, it is there for your protection. Your primer system should now be ready. Let's move on to Station 3.

Station 3: This is an easy one. All we do is seat the bullet to its proper depth in the cartridge case. This depth was adjusted at the factory for the bullet type on the sample cartridge.

We give you a choice of bullet seating stems, use the one closest to the type of bullet you are using.

The depth of bullet seating may be adjusted simply by screwing the seating stem in or out. The adjustment is held in place by a layer of Delrin beneath the toolhead.

Station 4: Another easy one. This station removes the bell and crimps the bullet in place. Once again this adjustment has been performed by Dillon.

More or less crimp can be achieved simply by screwing the crimp adjustment screw (#13908) in or out. Check your reloading manual for crimp dimensions.

Load 'em up

Okay now that you understand the purpose of all of the Square Deal "B" stations, we are ready to reload. Begin as follows:

1.) Place a clean, empty case in Station 1 and cycle the handle, don't forget to press forward firmly to seat the primer in Station 2. Work slowly.

2.) Place another empty case in Station 1, cycle the handle. Work slowly and carefully, watch the powder bar function and be sure it travels fully to the left each time. If it doesn't, turn the powder die (#13865) 1/8 turn clockwise and try again.

3.) Carefully place a bullet on top of the cartridge case at Station 3. Insert a new empty case at Station 1, cycle the handle.

4.) From this point on, place a bullet on the case at Station 3 with your left hand. Insert a case at Station 1 with your right hand and cycle the handle. Each time you cycle the machine a finished round will be ejected into the cartridge collection bin. (See Fig. 18 next page)

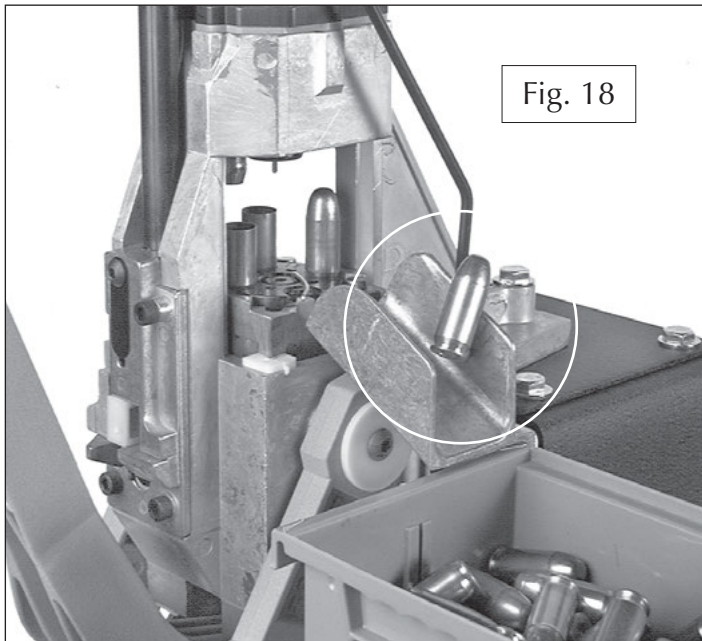

Fig. 18

Replacing the Wave Bearings

Over time, the four plastic wave bearings (#13630) may become worn. Follow these instructions to replace the wave bearings:

- 1.) Remove any primers from the primer system by removing the primer magazine tube (*#13879). Store live primers safely!
- 2.) Remove the three screws (#13989) that attach the primer system (*#20253 - see pg. 6) to the machine.
- 3.) Remove the primer system from the machine.
- 4.) Disconnect the failsafe rod (#16814) by unclipping it at the powder measure bellcrank.
- 5.) Remove the index bolt (#13461), located at the back of the frame below the mounting surface. It may be necessary to remove the machine from the bench to access this bolt.
- 6.) Remove the four screws (#13896) which hold the link arms (#13822) to the frame.
- 7.) Support the shaft (#13437) with one hand and remove the link arms.
- 8.) Withdraw the shaft from the bottom of the frame (#13445).
- 9.) Now the four wave bearings can be removed from the inside of the frame and the replacements fitted.
- 10.) Reassembly is the reverse of the above procedure.

Square Deal "B" Conversion Instructions

Changing calibers on your SDB is a simple procedure.

First, you must decide whether you need to change the priming system that is now set up on your machine. Small calibers use small pistol primers and large calibers use large pistol primers. Skip step one if there are no primer size changes.

Step 1: Changing The Priming System

Remove Primer Early Warning System. Remove three screws (#13989 – refer to schematic) to remove the primer system from the front of the machine. Remove the

primer slide return spring from pin (#13790) and remove the primer slide assembly from the magazine system. Replace the correct size primer slide in the same manner.

IMPORTANT Make sure the magazine is empty of all primers by inverting the primer assembly.

Remove cap (#13957) and pull out the internal magazine tube (#13673). Take the correct size magazine tube and drop a primer, anvil side up, into the top of the tube to make sure the primer drops freely through the tube and orifice. Insert the magazine tube (#13673) into the magazine shield with the keyed side of the orifice pushed all the way down into the notch or key way in the housing (#20900). Replace the cap (#13957). Do not over tighten!

Now, insert a few primers, anvil side up, into the magazine. Pull the handle, a full stroke, raise the handle and a primer should appear at Station 2. If a primer fails to appear, adjust the primer feed adjustment screw (#13961a), located at the lower tip of the flat spring (#13979) on the front of the housing (#20900) as follows:

If changing from a large primer to a small primer turn the primer feed adjustment screw (#13961a) in 1/8 turn increments clockwise. If changing from small to large, turn in 1/8 turn increments counterclockwise.

Cycle the handle again and a primer should appear. If the primer cup is not centered under the shellplate or snaps into place when the handle is raised it may be necessary to adjust the primer slide travel by turning the slide stop adjustment screw (#13961b) in 1/8 turn increments. It is located between the primer slide and the coiled spring (#13798) on the front on the housing. (see pgs 3 & 4.)

Step 2: Changing Shellplates

Lift out the ejector wire (#13433) and remove the shellplate bolt (#13328). Carefully remove the shellplate and be aware of a very small index ball (#14019) that sits on a spring. Install the correct shellplate.

The short end of the ejector wire fits behind the shellplate bolt (#13328). Note: The correct positioning of the ejector wire is important or serious damage to the sizing die could result. See Fig. 6.

Step 3: Changing and Adjusting Dies

Use of Dillon's Bench Wrench is suggested when changing or adjusting dies.

Remove screw (#13895) and remove the powder measure. Remove screws (#13815) and (#14037) and remove the toolhead assembly. Lift out the three die inserts (#12864, #11628, #11734) from the frame. Note: The toolhead you just removed is adjusted for those dies. Store these parts for when you set up this caliber again.

Now, take the dies of the caliber that you are converting to and insert them into the frame, corresponding to the position reference number on each die. 1, 3 & 4. If you choose to use the toolhead you removed, be certain that you back out the adjustment bolt (#13908) at Station 4 and remove the seating stem at Station 3.

Reinstall the toolhead with screws (#13815).

Drop the correct powder funnel expander in the die body (#13865) and mount the powder measure just as you removed it. Loosen the clamp screw (#13895).

To achieve proper adjustment of the die it is important to understand that the adjustable powder bar should reach the end of its travel at the same time that the handle reaches the bottom of its stroke against the frame stops.

To achieve this adjustment, start with the die body (#13865) three turns into the toolhead (#13712). Place an empty case in the shellplate at station 2 and pull the handle downward. Watch the movement of the powder bar on the powder measure. If the powder bar does not travel completely by the time the handle reaches the bottom of its stroke, raise the handle halfway and turn the die body (#13865) downward one turn. Pull the handle down again, watching the movement of the powder bar. Repeat these steps as necessary until the powder bar reaches the limit of its travel at the same time the handle reaches the bottom of its stroke.

Once this has been achieved, to flare the case mouth, the powder die must be turned downward from this point in 1/4 turn increments until the case has about .015-.020" flare on the case mouth. This can be checked with dial calipers. The base of the bullet needs only to set within a slightly flared case mouth.

Beware! If you pull the handle and the powder bar reaches the end of its travel before the handle reaches the bottom of its stroke, STOP! Raise the die (#13865) several turns and try again. Once the adjustment is correct but you want the case mouth flared a little more, just screw die (#13865) down 1/4 turn or less.

The base of the bullet needs only to set within a slightly flared case mouth.

Tighten screws (#14037) and (#13895).

Now, you can adjust the powder measure for the charge your loading data tells you to use. Remember that the powder charge adjustment screw (#13943, see **Fig. 13**) turns counterclockwise to decrease the volume of charge and clockwise to increase the charge.

Your conversion kit comes with the seating stems to fit the most popular bullet styles; wadcutters, semi-wadcutters and round nose. Choose one and insert it in Station 3. Simply seat the bullet to a desired depth. Consult your loading data!

Now, index your seated cartridge to Station 4. Lower the handle all the way against the frame stops. Turn the die adjustment bolt (#13908) down until you feel a slight opposition. Raise the handle and turn the adjustment bolt clockwise 1/4 to 1/2 a turn. Insert this cartridge back into the shellplate at Station 4 and give the handle a full stroke. The crimping die is now adjusted and you're ready to start loading.

Reloading Tips:

If you're using new unfired brass remove the sizing die (#12864). Virgin brass usually does not require full length sizing. (Optional)

Always give the handle a FULL STROKE or remove all cases and start over, as operations may be only partially completed.

Use cleaned brass or damage to dies may result. Avoid the use of military brass with crimped primer pockets. Crimps can easily be removed with a Dillon SS-600 Swager.

Mount the machine on a sturdy work bench that will not move while loading. Bench movement will impair your ability to prime correctly. Suggestion: Nail or screw your bench directly to your wall.

REMEMBER!

Press forward firmly on the handle to seat your primers. Primer jams or misfeeds can be caused by misadjustment of the set screw (#13961a) in the primer feed block. The most common case of primer misfeeds or jams is the primer punch not seating fully onto the primer slide. This will cause the primer cup to strike the flexible orifice on the bottom of the primer magazine tube.

Watch the powder bar function, make sure you're getting powder.

Set the bullet straight on the case at Station 3 so that it enters the die correctly.

Watch your supply of powder and primers, you'll be using them faster than you think you are.

Take your time and learn the machine and its function. The Square Deal "B" will deliver hundreds of trouble free rounds in short order, just relax and take your time in the beginning.

Keep it clean – primer residue, spilled powder and just plain dirt can jam your machine. All bearing surfaces are Delrin and require no lubrication.

Clean your powder bar and underneath your shellplate about every 500 rounds. Some powders build up and will eventually stick the powder bar. Paint or lacquer thinner works well to remove any build up.

Friend at the Factory

We started this manual by saying if you have a problem, call us. We mean it. Anyone can make a mistake. There's no such thing as a dumb question. If something is giving you a problem, let us help you!

Technical Support: 1-800-223-4570
www.dillonprecision.com

NOTICE: This machine is designed specifically to be a manually operated handloading machine. Any attempts to mechanize this product will void the warranty. We specifically warn against converting this product to automated or motorized operation.

All Dillon machines are warrantied for life from defects in material or workmanship, except the XL/Super 1050, plus a one year 100% warranty against normal wear. All electrical/electronic components in Dillon equipment are covered by a one year warranty.

SDB Caliber Conversion Chart

.32 S&W Long, .32 H&R Magnum - #16774

#D Shellplate - #12507
#S Powder Funnel - #12845
#SW Powder Funnel - #13171
#3 Locator Pin (4) - #14060
Sizer Die .32 S&W - #22222
Seater Die .32 S&W - #16543
Crimp Die .32 S&W - #16544
Seat Stem .32 S&W WC - #16775
Seat Stem .32 S&W RN - #16824

.380 Auto - #20246

#3 Shellplate - #12906
#F Powder Funnel - #13806
#3 Locator Pin (4) - #14060
Sizer Die 380 Auto - #22207
Seater Die 380 Auto - #12198
Crimp Die 380 Auto - #11870
Seat Stem 9mm SWC - #11302
Seat Stem 9mm RN - #12313

.38 Special, .357 Magnum - #20240

#2 Shellplate - #13635
#D Powder Funnel - #13599
#2 Locator Pin (4) - #14062
Sizer Die .38/.357 - #22201
Seater Die .38/.357 - #12673
Crimp Die .38/.357 - #12279
Seat Stem .38/.357 SWC - #12158
Seat Stem .38/.357 WC - #11647
Seat Stem .38/.357 RN - #11429

.38 Super - #20229

#5 Shellplate - #13440
#F Powder Funnel - #13806
#3 Locator Pin (4) - #14060
Sizer Die .38 Super - #22208
Seater Die .38 Super - #12345
Crimp Die .38 Super - #12473
Seat Stem 9mm SWC - #11302
Seat Stem 9mm RN - #12313

9mm Parabellum - #20241

#5 Shellplate - #13440
#F Powder Funnel - #13806
#3 Locator Pin (4) - #14060
Sizer Die 9mm - #22206
Seater Die 9mm - #11525
Crimp Die 9mm - #12497
Seat Stem 9mm SWC - #11302
Seat Stem 9mm RN - #12313

10mm, .40 S&W - #20469

#W Shellplate - #13523
#W Powder Funnel - #13600
#2 Locator Pin (4) - #14062
Sizer Die 10/.40 - #22209
Seater Die 10/.40 - #12276
Crimp Die 10/.40 - #11801
Seat Stem 10/.40 SWC - #12124
Seat Stem 10/.40 Trun - #12313

.41 Magnum - #20247

#6 Shellplate - #13284
#H Powder Funnel - #13240
#1 Locator Pin (4) - #13930
Sizer Die .41 Mag - #22202
Seater Die .41 Mag - #11794
Crimp Die .41 Mag - #11799
Seat Stem .41 Mag SWC - #12067

.44 Special, .44 Magnum - #20242

#4 Shellplate - #13504
#G Powder Funnel - #13427
#4 Locator Pin (4) - #14047
Sizer Die .44 Mag - #22203
Seater Die .44 Mag - #11863
Crimp Die .44 Mag - #13036
Seat Stem .44 Mag SWC - #11880
Seat Stem .44 Mag RN - #12571

.44/40 Winchester - #20135

#N Shellplate - #13095
#.44/40 Powder Funnel - #13474
#4 Locator Pin (4) - #14047
Sizer Die .44/40 - #10853
Seater Die .44/40 - #10722
Crimp Die .44/40 - #10847
Seat Stem .44 Mag SWC - #11880

.45 ACP, .45 GAP - #20123

#1 Shellplate - #13653
#E Powder Funnel - #13782
#1 Locator Pin (4) - #13930
Sizer Die .45 ACP - #22204
Seater Die .45 ACP - #11628
Crimp Die .45 ACP - #11734
Seat Stem .45 ACP SWC - #11303
Seat Stem .45 ACP RN - #12476

.45 Colt - #20248

#C Shellplate - #13112
#E Powder Funnel - #13782
#4 Locator Pin (4) - #14047
Sizer Die .45 LC - #22205
Seater Die .45 LC - #12306
Crimp Die .45 LC - #12588
Seat Stem .45 LC SWC - #12619
Seat Stem .44 Mag RN - #12571

.45 S&W Schofield - #20417

#C Shellplate - #13112
#E Powder Funnel - #13782
#4 Locator Pin (4) - #14047
Sizer Die .45 LC - #22205
Seater Die .45 LC - #12306
Crimp Die .45 Schofield - #11253
Seat Stem .45 RN Schofield - #11210

Note: This chart does not list all parts included in a conversion kit.

On the cover...

The Square Deal B is pictured with optional accessories:

SDB Strong Mount #22223

Low Powder Sensor #16306

Other accessories available for the Square Deal B include:

Bullet Tray #22214

Machine Cover #13795

Maintenance Kit & Spare Parts Kit #97015

The **Blue Press**, Dillon's monthly catalog, has a complete listing of accessories available for all machines.

Dillon Precision Products, Inc.

8009 E. Dillon's Way
Scottsdale, AZ 85260

(480) 948-8009

FAX (480) 998-2786

www.dillonprecision.com

Technical Support E-Mail: dillon@dillonprecision.com

Technical Support & Customer Service

(800) 223-4570

